

- Presentation & options
- E Sections
- Fonctionning
- Booms for fuling mast
- Mastheads for fuling mast

- Présentation & options
- Profils E
- Fonctionnement
- Bômes pour mât enrouleur
- Têtes de mât enrouleur





The SPARCRAFT manual stoway masts work with a tried and tested worm drive reefing system. In addition Sparcraft can offer a hydraulic or electric drive system to make reefing even easier.



Les mâts enrouleurs manuels SPARCRAFT - Gamme E - utilisent des systèmes d'enroulement à vis sans fin. Sparcraft propose aussi des assistances hydrauliques ou électriques pour un plus grand confort d'utilisation.

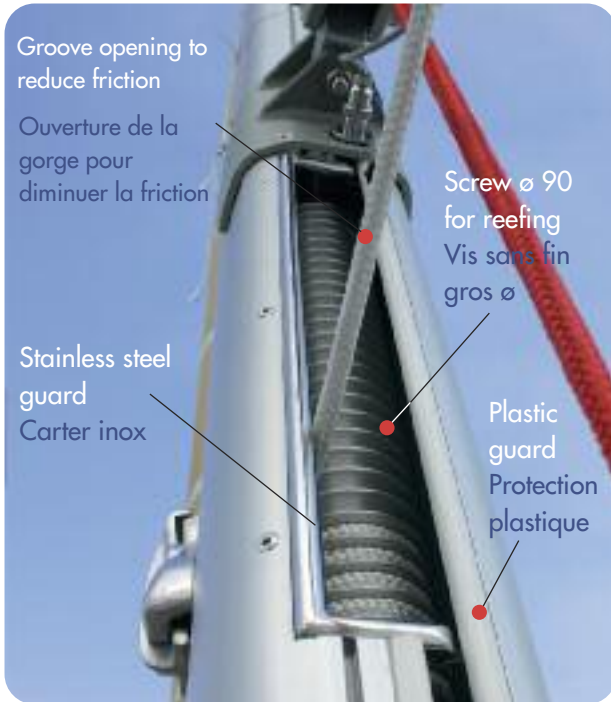

SYSTÈME MANUEL / MANUAL SYSTEM

- Reefing the sail at the luff reduces the sail area rapidly.
- No sail on the boom for arrival in port : provides greater visibility.
- L'enroulement de GV par le guindant entraîne une réduction efficace de sa surface.
- Pas de voile sur la bôme : offre davantage de visibilité pour les arrivées au port.



ASSISTANCE HYDRAULIQUE OU ELECTRIQUE /OPTION : HYDRAULIC OR ELECTRIC DRIVE

- On request :
- Hydraulic assistance to standard control or "tele" control
- Power assisted (12 or 24V) with relay box (Boxtron deviation) and available in two versions: "tele" and "radio control"
- Possibility of Use in the manual position independently.

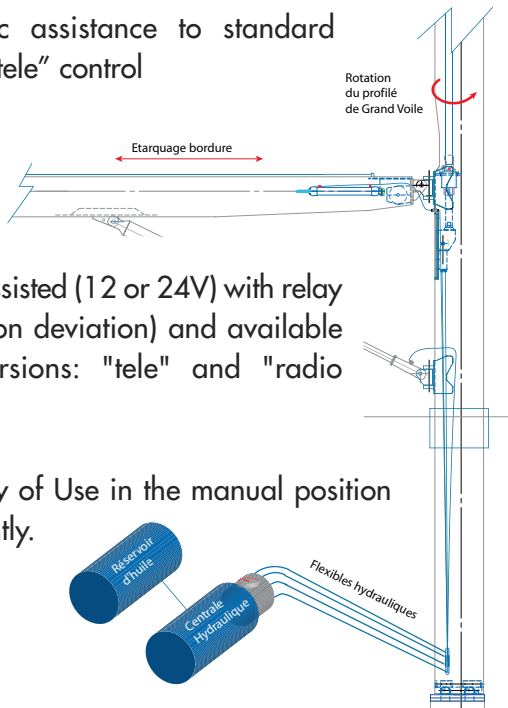

- Sur demande :
- Assistance électrique (12 ou 24 V) avec boîte à relais (type Boxtron) et disponible en deux versions : "télécommande" et "radio commande"
- Assistance hydraulique à commande classique ou version télécommande
- Possibilité d'utilisation en position manuelle indépendamment.



example (non contractual) / exemple (non contractuel)



E - SECTIONS / SECTIONS E

■ Extensive and scalable range up to 76' (see also 17883 and 26711 custom models)

■ Gamme très étendue et échelonnée jusqu'à 76' (Voir également modèles custom : sections 17883 et 26711)



■ The extrusions also have an external aft groove to be fitted either with a storm sail with sliders;

■ Les profils de mât sont équipés d'une gorge extérieure arrière destinée à recevoir une voile de tempête à coulisseaux;

■ The compatibility between the S range and F range allows the shipyards to fit their boats with either a standard or a furling mast, with the same mast step and deck collars.

■ Compatibilité entre gamme standard "S" et Enrouleur "E" permettant de monter les mâts avec les mêmes emplantures ou colerettes de pont Sparcraft.

■ Special goosenecks for furling masts : see p. 42

Gooseneck (reinforced, according to the specifications of the boat)
Vit de mulet (renforcé suivant spécif. bateau)



■ Vit de mulet adaptés : voir p. 42

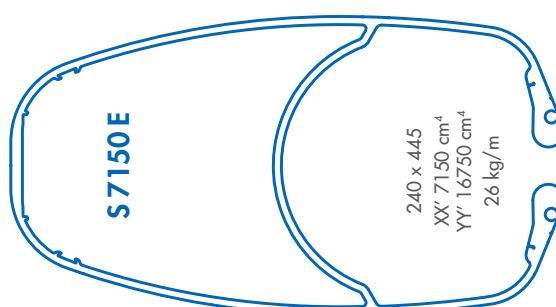
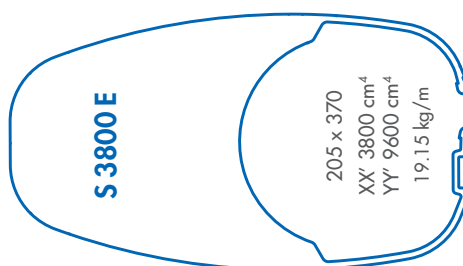
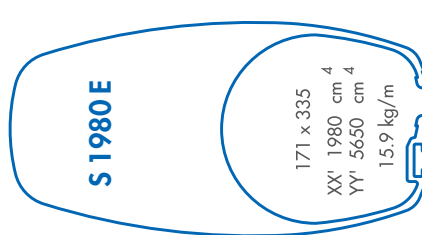
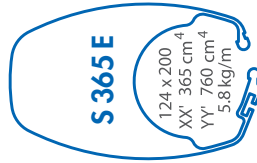
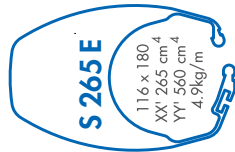

■ Careful details and reliability of peripheral parts

■ Détails soignés et fiabilité des pièces périphériques

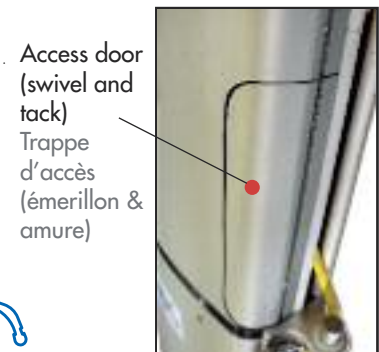

Access door (swivel and tack)
Trappe d'accès (émerillon & amure)



FONCTIONNEMENT / FUNCTIONING

- Perfect lead of the rope (controlled from cockpit) with a worm drive;
- The worm drive transmits the rotation in which the main sail is reefed;

- Guidage parfait de la drosse (commandée du cockpit en mode manuel) par une vis sans fin;
- La vis sans fin transmet la rotation au profil d'enroulement dans lequel est enroulée la Grand Voile;

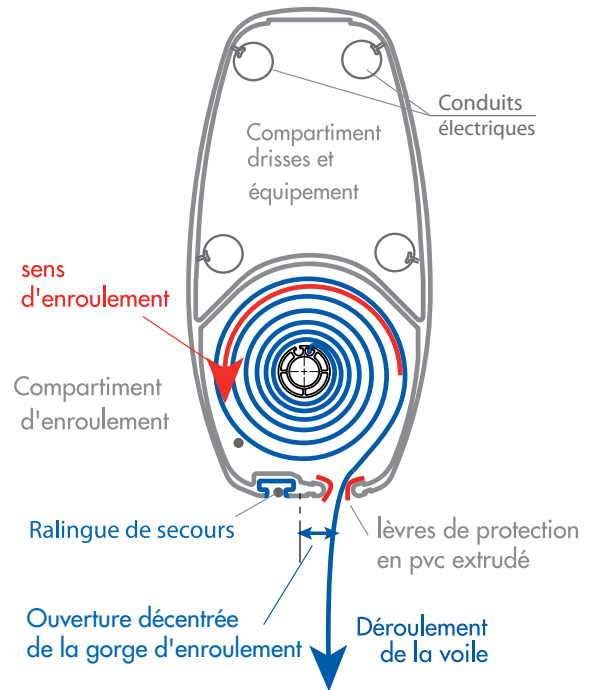
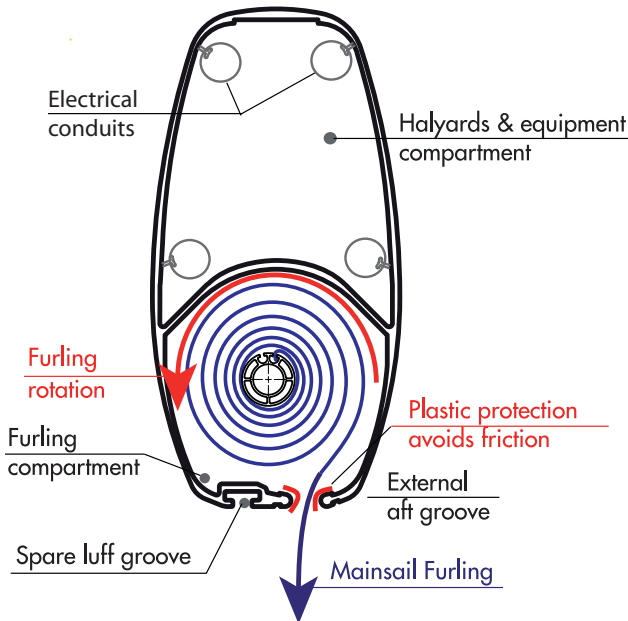

- Plastic protection is clipped to the edge of the sail groove, this reduces wear to the main sail and minimizes noise (when the sail is out).



- Protections plastiques : celles-ci sont clip-sées sur l'ouverture décentrée de la gorge d'enroulement. Elles évitent une usure prématurée de la GV et limitent le bruit (une fois la GV dépliée).

BÔMES pour MÂTS ENROULEURS / BOOMS for FURLING MASTS

- All our booms (see P. 64) can be fitted with tracks + cars or directly with roller cars (standard kit) for the outhaul tightening.



- Toutes nos bômes (voir p. 64) peuvent être équipées de rails + chariots ou directement de chariots à galets (montage standard) pour l'étarquage de la bordure.



MASTHEADS FOR FURLING MASTS / TÊTES DE MÂT ENROULEUR

■ Masthead non tapered for mastead rig

■ Tête de mât non rétreint pour Gréement en tête

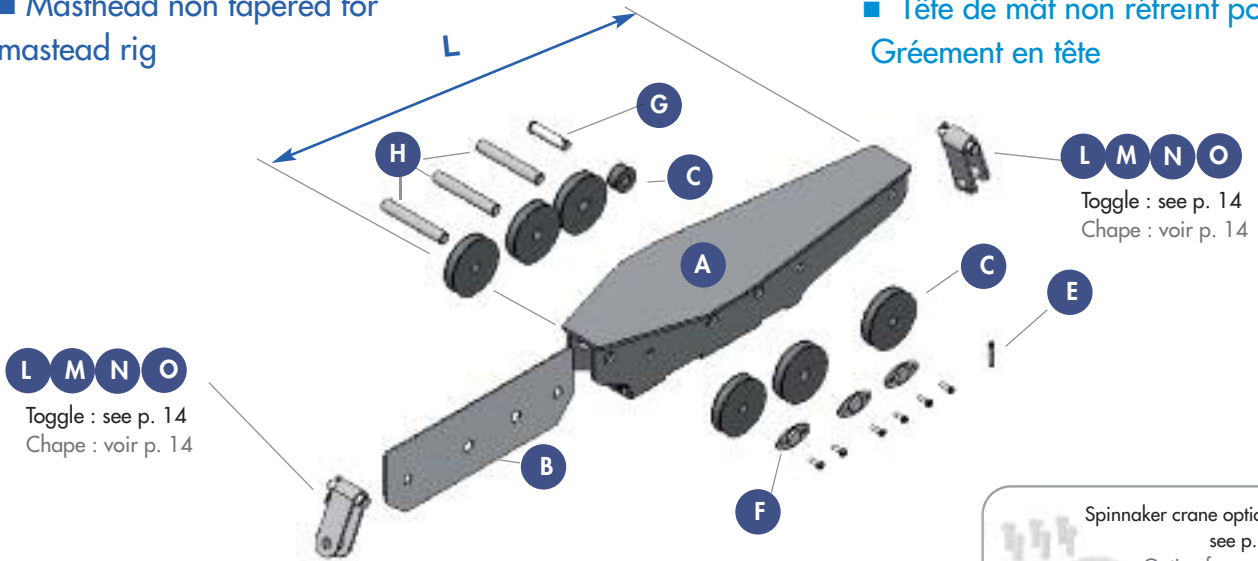

Toggle : see p. 14
Chape : voir p. 14

Spinnaker crane option : see p. 15
Option ferrure de spi voir : p. 15

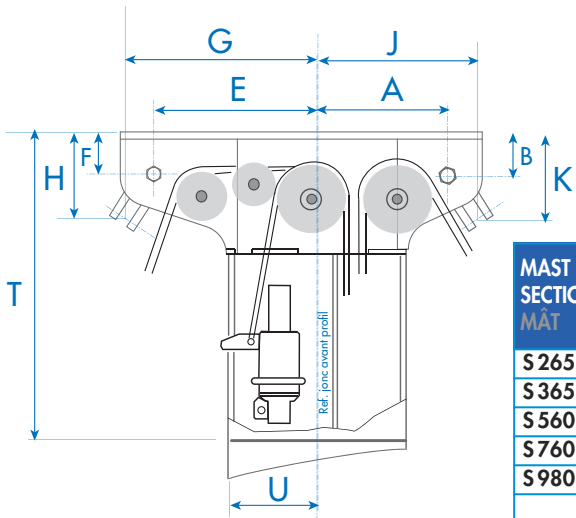

SPECIFICATIONS / CARACTÉRISTIQUES DIMENSIONNELLES

MAST SECTION MÂT	MASTHEAD TÊTE DE MÂT PART NUMBER REFERENCE	ø TOGGLES ø AXE CHAPE	DIMENSIONS					
			G	H	J	K	T	U
S 265 E	30003014245	Ø12	229	86	171	88	350	82
S 365 E	30003014445	Ø12	239	86	181	88	350	88
S 560 E	30003014555	Ø12 / Ø16	262	86	169	88	450	91
S 760 E	30003014925	Ø16 / Ø18	271	86	197	88	470	110
S 980 E	30003015185	Ø16 / Ø18	276	86	218	88	500	115
			E	F	A	B	T	U
S 1410 E	30006016335	ø 14,5 mini	311	40	237	40	500	126
S 1980 E	30006016805	ø 16,5 mini	363	40	247	40	500	140

MASTHEADS PARTS / ÉLÉMENTS DES TÊTES DE MÂT

MAST SECTION / MÂT		S265E	S365E	S560E	S760E	S980E	S1410E	S1980E
Pict / Repères	SECTION n°	3	3	3	3	3	6	5
	BODY n°	3	3	3	3	3	6	5
	LONGUEUR mm	424	444	455	492	520	618	680
	CODE COMPLET	30003014245	30003014445	30003014555	30003014925	30003015185	30006016335	30006016805
	DESIGNATION	DESCRIPTION	CODE	QT	CODE	QT	CODE	QT
A	CORPS	BODY	30003014243	1	30003014443	1	30003014553	1
B	CLOISON	CHEEK	30003114243	1	30003114445	1	30003114553	1
C	REAS	SHEAVES	48510651625	6	48510651625	1	48510501625	1
			48510401516	1	48510401516	1	48685151200	2
			48660151200	5	48660151200	4	48510651625	2
G	AXE INOX ÉPAULÉ	CLEVIS PIN	40020212052	2	40020212052	2	40020212052	1
H	AXE DROIT	PIN	40020112090	2	40020112090	2	40020112080	1
			40020112065	1	40020112105	2	40020112120	2
F	CACHE AXE	PIN PROTECT.	41201020105	2	41201020105	3	41201020105	3
E	GOUPILLE	SAFETY PIN	28803032320	2	28803032200	2	28803032200	1
E	RONDELLE	WASHER					28601018000	1
-	VIS	SCREW						28600704020
-	BOUCHON FEU	LIGHTS COVER						43093000001

■ Masthead non tapered for 7/8 mastheads

■ Tête de mât non rétreint pour gréement 7/8

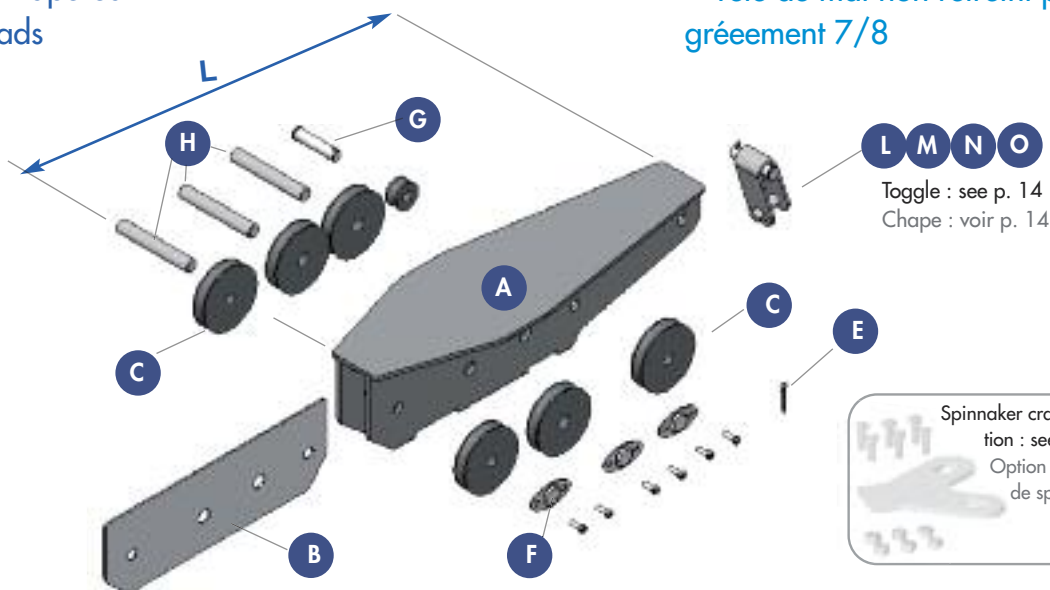

Toggle : see p. 14
Chape : voir p. 14

Spinnaker crane option : see p. 15
Option ferrure de spi voir : p. 15

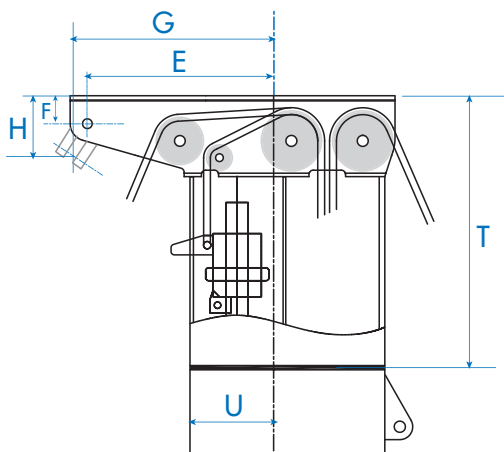

SPECIFICATIONS / CARACTÉRISTIQUES DIMENSIONNELLES

MAST SECTION MÂT	MASTHEAD TÊTE DE MÂT Part number Référence	Ø TOGGLES Ø AXE CHAPE	DIMENSIONS			
			G	H	T	U
S 265 E	30004063745	Ø8 / Ø10	225	86	350	82
S 365 E	30003063975	Ø10 / Ø12	239	86	350	88
S 560 E	30003253605	Ø12	240	86	450	91
S 760 E	30003064445	Ø12	271	86	470	110
S 980 E	30003064685	Ø16 / Ø18	271	86	500	115
			E	F	T	U
S 1410 E	30006015465	Ø 14,5 mini	310	40	500	126
S 1980 E	30006036145	Ø 16,5 mini	360	40	500	140

ÉLÉMENTS DES TÊTES DE MÂT / MASTHEADS PARTS

MAST SECTION / MÂT		S265E	S365E	S560E	S760E	S980E	S1410E	S1980E									
Pict/ Repères	SECTION n°	4	3	3	3	3	6	6									
	BODY n°																
	LONGUEUR mm	374	397	405	446	468	545	614									
	CODE COMPLET	3000 4063 745	3000 3063 975	3000 3253 605	3000 3064 445	3000 3064 685	3000 6015 465	3000 6036 145									
	COMPLETE CODE																
	DESIGNATION	DESCRIPTION	CODE	QT	CODE	QT	CODE	QT									
	A	CORPS	BODY	30004063742	1	30003014443	1	30003064053	1	30003064442	1	30003064682	1	30006015463	1	30006036142	1
	B	CLOISON	CHEEK	30004163743	1	30003114445	1	30003164053	1	30003164445	1	30003164682	1	-	-	-	-
	C	REAS	SHEAVES	48510251225	1	48660151200	5	48660151200	4	48510651625	2	48510651625	2	48510652125	1	48510902125	3
				48510601225	3	48510651625	1	48510401516	1	48510501625	1	48510501625	1	48510902125	4	48511102125	3
				48660131000	3	48510501625	1	48685151200	2	48685151200	4	48685151200	4	48511102125	1		
	G	AXE INOX ÉPAULÉ	CLEVIS PIN	40020210040	2	40020212052	2	40020212052	2	40020212052	1	40020212052	1	40020218078	1	40020218078	1
	H	AXE DROIT	PIN	40020112080	2	40020112090	2	40020112080	1	40020112080	1	40020112090	1	40020118080	1	40201181052	1
							40020112105	2	40020112105	2	40020112120	2	40201181052	2	40200118120	1	
															40201181322	1	
	F	CACHE AXE	PIN PROTECT.	41201020105	2	41201020124	3	41201020105	3	41201020105	3	41201020105	3	41201020205	3	41201020205	3
	E	GOUPILLE	SAFETY PIN	28803032200	2	28803032200	2	28803032200	1	28803032200	1	28803032200	1	28803040400	1	28803040400	1
	E	RONDELLE	WASHER										28601018000	1	28602318030	1	
	-	VIS	SCREW			28606408009	6								28600704020	2	
	-	BOUCHON FEU	LIGHTS COVER												43093000001	1	